

## PRODUCT DATA SHEET

# Distribution box with side connection

VCB160-10, VCB160-10/90

NOVELTY SYSTEM **Ø90**



TIGHTNESS CLASS



MATERIAL



BACTERIOSTATIC

The Awenta PRO distribution box allows the connection of up to 10 Ø75-90 ventilation ducts.

As with the other distribution boxes in the VCB series, unused spigots can be covered with plugs with gaskets included with the product. The box is characterised by a side connection with a diameter of Ø160 mm.

Distribution boxes with side connections are ideal for installation above suspended ceilings and wherever installation height is limited.

The suitably profiled shape of the Awenta PRO boxes allows for a quiet air flow, while ensuring low pressure loss.

The range of distribution boxes available has been carefully planned to allow their use in most typical mechanical ventilation systems.



VCB160-10

VCB160-10/90



## AIR FLOW CHARACTERISTICS

VCB160-10

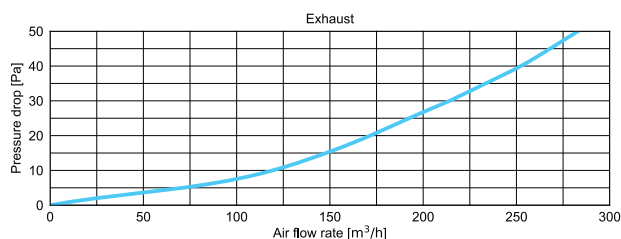
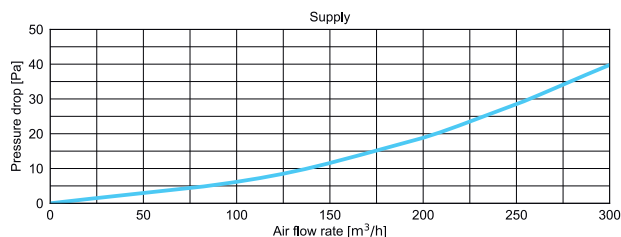

VCB160-10/90

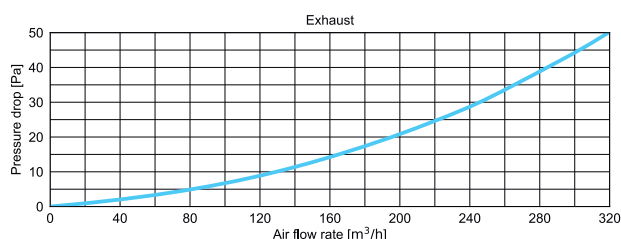
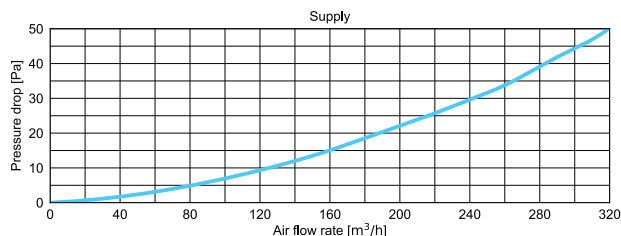

## DIMENSIONS

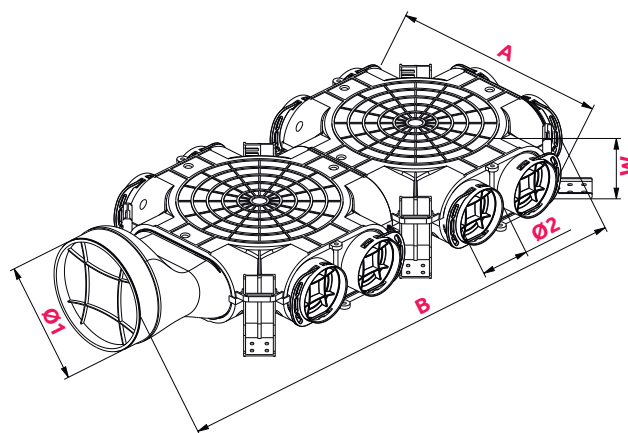

	Ø1	Ø2	A	B	W
VCB160-10	160	75	347	766	104
VCB160-10/90	160	90	407	795	104

WITH **NANOSILVER** ADDITIVE  
ELIMINATING UP TO **99%** BACTERIA

